

TruLaser:

Cost-effective
cutting through
thick and thin.



Up to the challenge.

Contents

Up to the challenge. _____	2
In the best hands. _____	4
Abundant choice. _____	6
TruLaser Series 1000 _____	8
TruLaser Series 3000 _____	12
TruLaser Series 5000 _____	16
TruLaser Series 7000 _____	20
TruLaser Series 8000 _____	24
Focused knowledge. _____	28
Automation that pays off. _____	32
Software: Programmed for success. _____	34
TruServices: Service like no other. _____	35

When you choose TRUMPF you choose the most expedient entry into the world of laser cutting. As the world market leader, TRUMPF provides everything from a single source: machine, laser, automation, software and services. Our comprehensive product range in the sheet metal processing chain is supported by a large international service network.

Whatever your requirements, our innovative technology will provide you with the most cost-efficient solution. Our equipment is so easy to operate that even with no experience you will quickly be able to cut the highest quality parts and benefit from the great advantages of the laser beam: Complete freedom in cutting contours across an extremely wide range of material types and thicknesses.

TruLaser: Benefits at a glance.

- 1 The most cost-efficient solution for every requirement.
- 2 The most innovative laser cutting technology.
- 3 Easy to operate.
- 4 Wide choice of contours, sheet thicknesses and materials.
- 5 Everything from a single source: machine, laser, automation, software.

Visit us on YouTube.
www.youtube.com/trumpftube





TruLaser Series 1000

Low cost, compact and operator-friendly machines. Its ability to fit in the smallest spaces combined with low investment and operating costs and easy operation are convincing features of the TruLaser Series 1000.



TruLaser Series 3000

Flexible standard machines. The flexibility and reliability of these genuine all-around machines is exceptional.



TruLaser Series 5000

Productive machines. These powerhouses set high standards of productivity and cost efficiency.



TruLaser Series 7000

High-performance machines. These machines stand for absolute top performance regarding both productivity and accuracy.



TruLaser Series 8000

Flexible oversize format machines. Built to deliver the highest cost efficiency and excellent part quality in the oversize range.

In the best hands.

Quality thrives in the right environment.

TRUMPF machines are renowned for their reliability and superb quality. That's because our high quality standards are deeply embedded in our corporate culture and are rigorously applied on a worldwide basis. Thanks to our SYNCHRO production system, we are continuously optimizing our processes, products and services. TRUMPF produces all of its machines on synchronized, standardized flow lines – because optimum quality can only be achieved through reliable processes.



Setting standards.

TRUMPF consistently invests in research and development at a level well above the industry average. Our innovative products and functions constantly set new standards in the field of laser processing. One example of this is BrightLine fiber – the quality breakthrough in solid-state laser cutting.

Making technology simple.

We are driven by our desire to make high-tech laser cutting available to everyone. That's why we focus on developing machines that are user-friendly and easy to operate. Installation, maintenance and programming can be performed without much effort. Many innovations make your everyday work easier: as an alternative to the control panel, the MobileControl app gives you the possibility of monitoring and controlling your machine.

Sustainable thinking.

We aim to run a cost-efficient and responsible business which makes efficient use of resources. For example, the tiny nozzle diameters of our lasers keep gas consumption to a minimum. With the TruFlow, we offer you the world's most efficient CO₂ laser. The universal cooling interface provides efficient machine cooling.

Best choice based on experience.

Our expertise in lasers is based on four decades of experience and the installation of more than 60,000 lasers worldwide. For each laser cutting machine, we carefully select the most suitable option among our eight different types of lasers. As the technology leader, we provide you with neutral, results-oriented advice to help you find the optimum and most cost-effective solution for your particular field of application.

Abundant
choice.





TruLaser Series 1000

Low cost, compact and operator-friendly machines.

These compact machines offer extremely low investment and operating costs combined with the ultimate in user-friendly operation. The dialog-based operating concept makes it quick and easy to find the function you need. It takes just a few hours to install a machine, so you will be cutting your first parts before you know it.





Benefits at a glance.

- 1 Low investment and operating costs.
- 2 Very easy to operate.
- 3 Small footprint of only 25 m².
- 4 Quick and easy installation.
- 5 Affordable entry into laser welding.

TruLaser Series 1000



Laser cutting for less.

Low shipping and space costs.

Shipping is easy and therefore inexpensive. With their compact footprint, the machines of the TruLaser Series 1000 are delivered in just one standard container. Its footprint of just 25 m² also saves on space related costs.

Minimal setup and installation costs.

It takes just a few hours to get one of our machines up and running, reducing installation and setup costs. The machine's low weight requires a floor thickness as low as 100 mm, and the machine does not need to be anchored to the floor, so no drilling is required.

Simple to operate.

The operating concept allows you to choose between beginner and advanced level. With the beginner level, only the keys needed for fast part cutting are visible. The machines of the TruLaser Series 1000 ensure operation is safe even if you have never used a laser machine before. At the advanced level, you can easily adjust all the technological settings yourself.

Low training costs.

The intuitive operating system in the TruLaser Series 1000 is quick and easy to learn – so you can keep training costs to a minimum.

Machine data		
	TruLaser 1030	TruLaser 1030 fiber
Working range		
X axis	3000 mm	3000 mm
Y axis	1500 mm	1500 mm
Z axis	75 mm	75 mm
Workpiece		
Max. weight	720 kg	720 kg
Max. speed		
Simultaneous	85 m/min	85 m/min
TRUMPF CNC control		
	B&R	B&R
Accuracy^[1]		
Position deviation P _a	0.1 mm	0.1 mm
Average position scatter P _{s max}	0.03 mm	0.03 mm
Dimensions and weight^[2]		
Length	7400 mm	7800 mm
Width	2800 mm	2800 mm
Height	2300 mm	2900 mm
Weight	9730 kg	10400 kg
Available lasers		
	TruCoax 2500	TruDisk 2001/3001

^[1] Position scatter information is given in reference to the entire working length. Positional accuracy is measured and approved according to VDI/DGQ 3441.

^[2] Approximate values (TruDisk not included): The exact figures can be obtained from the applicable installation plan.

Subject to alteration. Only specifications in our offer and order confirmation are binding.

Laser data			
	TruCoax 2500	TruDisk 2001	TruDisk 3001
Max. power	2500 W	2000 W	3000 W
Wavelength	10.6 µm	1.03 µm	1.03 µm
Max. sheet thickness			
Mild steel	16 mm	16 mm	20 mm
Stainless steel	8 mm	8 mm	16 mm
Aluminum	6 mm	6 mm	12 mm
Copper	–	3 mm	4 mm
Brass	–	3 mm	4 mm
Power consumption			
Average power consumption during production	26.9 kW	11.5 kW	12.9 kW
Active auto-shutdown	1.4 kW	0.4 kW	0.5 kW

Subject to alteration. Only specifications in our offer and order confirmation are binding.

TruLaser Series 3000

Flexible standard machines.

These versatile laser cutting machines provide outstanding flexibility and reliability. The TruLaser Series 3000 is based on a remarkably simple operating and maintenance concept and offers numerous options to enhance its versatility. The use of a single cutting head for all sheet thicknesses eliminates the need to change cutting heads when you switch to a different type of sheet. And the adjustable control panel features convenient and intuitive touch operation to guide you through the program functions.





Benefits at a glance.

- 1 First-class processing flexibility.
- 2 High cutting speeds and minimal downtime.
- 3 Low and easy maintenance.
- 4 A high level of operator ergonomics.
- 5 Various automation options.

TruLaser Series 3000

Easy to operate and endlessly versatile.

These machines are designed to be easy to operate and maintain. The components are clearly marked and easily accessible. This makes maintenance even easier, so you can get the machine running again even faster. The machines also offer the ability to incorporate many additional functions, helping you to respond with flexibility to changing needs and minimize unproductive time.



You can cut tubes on your CO₂ and solid-state laser cutting systems using the RotoLas, an auxiliary device.

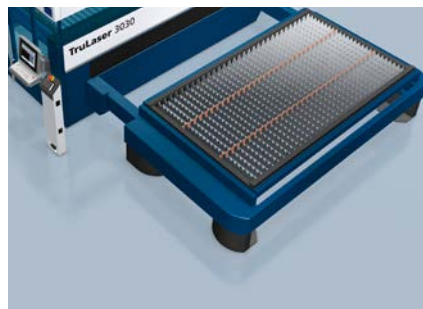

The side positioning of the pallet changer cuts the footprint by about 20 percent.



The technology package for lens and nozzle automation greatly simplifies lens and nozzle operation.



TruLaser 3030 fiber with BrightLine fiber: a new dimension.

The BrightLine fiber option catapults your production to new heights: it enables the solid-state laser to cut even thick mild steel in outstanding quality. In addition to the huge variety of materials and sheet thicknesses that can be processed, you benefit from more stable processes, tiny contours, and the supremely easy removal of finished parts.

Machine data						
	TruLaser 3030	TruLaser 3040	TruLaser 3060	TruLaser 3030 Lean Edition	TruLaser 3030 fiber	TruLaser 3040 fiber
Working range						
X axis	3000 mm	4000 mm	6000 mm	3000 mm	3000 mm	4000 mm
Y axis	1500 mm	2000 mm	2000 mm	1500 mm	1500 mm	2000 mm
Z axis	115 mm	115 mm	115 mm	115 mm	115 mm	115 mm
Workpiece						
Max. weight	900 kg	1700 kg	2000 kg	900 kg	900 kg	1700 kg
Max. speed						
Simultaneous	140 m/min	140 m/min	85 m/min	140 m/min	140 m/min	140 m/min
TRUMPF CNC control	Siemens Sinumerik 840D SL	Siemens Sinumerik 840D SL	Siemens Sinumerik 840D	Siemens Sinumerik 840D SL	Siemens Sinumerik 840D SL	Siemens Sinumerik 840D SL
Accuracy^[1]						
Position deviation P_a	0.05 mm	0.05 mm	0.05 mm	0.05 mm	0.05 mm	0.05 mm
Average position scatter $P_{s, max}$	0.03 mm	0.03 mm	0.03 mm	0.03 mm	0.03 mm	0.03 mm
Dimensions and weight^[2]						
Length	9300/6000 ^[3] mm	12000 mm	16100 mm	6300 mm	8800 mm	11400 mm
Width	4700/7600 ^[3] mm	5300 mm	5200 mm	5600 ^[4] /7200 mm	6010 mm	6730 mm
Height	2200/2200 ^[3] mm	2200 mm	2000 mm	2200 mm	2400 mm	2400 mm
Weight	12000 kg	13000 kg	21500 kg	12000 kg	12000 kg	12240 kg
Available lasers	TruFlow 3200/4000 5000/6000	TruFlow 3200/4000 5000/6000	TruFlow 3200/4000	TruFlow 3200/4000	TruDisk 3001/4001	TruDisk 3001/4001

^[1] Position scatter information is given in reference to the entire working length. Positional accuracy is measured and approved according to VDI/DGQ 3441.

^[2] Approximate values. The exact figures can be obtained from the applicable installation plan.

^[3] Applicable when the pallet changer is in the transverse position.

^[4] Width during processing with pallet guides-folded in.

Subject to alteration. Only specifications in our offer and order confirmation are binding.

Laser data						
	TruFlow 3200	TruFlow 4000	TruFlow 5000	TruFlow 6000	TruDisk 3001	TruDisk 4001
Max. power	3200 W	4000 W	5000 W	6000 W	3000 W	4000 W
Wavelength	10.6 μm	10.6 μm	10.6 μm	10.6 μm	1.03 μm	1.03 μm
Max. sheet thickness						
Mild steel	20 mm	20 mm	25 mm	25 mm	20 mm	20/25 ^[5] mm
Stainless steel	12 mm	15 mm	20 mm	25 mm	15 mm	20 mm
Aluminum	8 mm	10 mm	12 mm	15 mm	15 mm	20 mm
Copper	–	–	–	–	6 mm	8 mm
Brass	–	–	–	–	6 mm	8 mm
Power consumption						
Average power consumption during production	29.0 kW	29.3 kW	35.3 kW	36.5 kW	12.2 kW	14.3 kW
Active auto-shutdown	0.8 kW	0.8 kW	0.8 kW	0.8 kW	0.5 kW	0.5 kW

^[5] With BrightLine fiber.

Subject to alteration. Only specifications in our offer and order confirmation are binding.

TruLaser Series 5000

Productive machines.

These powerhouses set high standards of productivity and cost efficiency. This is made possible by dynamic drives, high axis speeds and a high degree of automation. BrightLine and BrightLine fiber guarantee maximum part quality for all sheet thicknesses within the fields of CO₂ and solid-state laser technology. Thanks to its innovative cooling concept, the CO₂ laser is the best of its class when it comes to efficiency.



Awards for TruLaser 5030 fiber:





Benefits at a glance.

- 1 Maximum productivity across the entire parts spectrum.
- 2 Maximum part quality for all sheet thicknesses.
- 3 Maximum process reliability in fully automatic operation.
- 4 Highest energy efficiency.
- 5 High axis speed and positioning dynamics.

TruLaser Series 5000

Real powerhouses.

These highly productive machines effortlessly process both thick and thin sheets. Using TruDisk 8001 and our highly dynamic drives, you can obtain maximum productivity across the entire sheet thickness spectrum. With a laser power of up to 8,000 W, TruFlow cuts even stainless steel at thicknesses of 50 mm.

Designed for maximum capacity utilization, the machines reach axis speeds of 300 m/min. A wide variety of automation solutions and smart functions guarantee reliable processes in automatic mode.

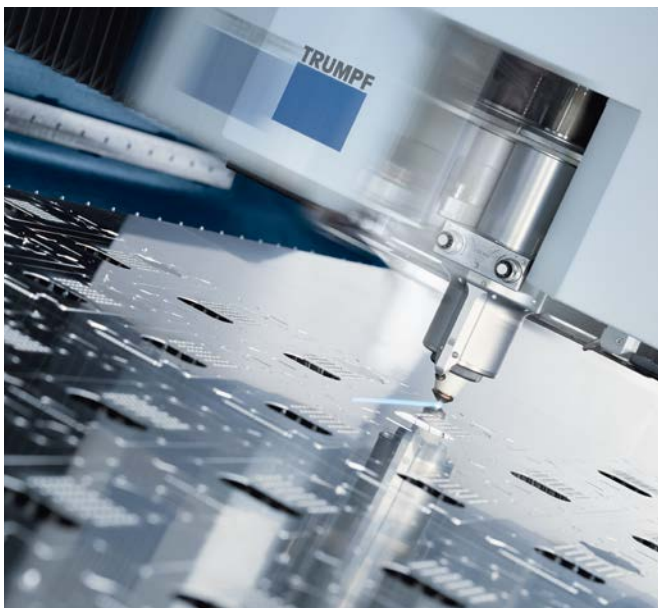

High productivity for optimized costs per part.

Innovative cutting methods.

Thanks to BrightLine fiber, you achieve top-quality cutting results across the entire spectrum of materials and sheet thicknesses. CoolLine allows you to cut grades and geometries of thick mild steel that were previously impossible.

Unbeatable efficiency.

The TruFlow owes the best energy balance in the world to an innovative high-temperature cooling system. Power consumption can thus be reduced by up to 30%.



BrightLine fiber guarantees maximum part quality in stainless steel with thicknesses of 25 mm and more.

Machine data					
	TruLaser 5030	TruLaser 5040	TruLaser 5060	TruLaser 5030 fiber	TruLaser 5040 fiber
Working range					
X axis	3000 mm	4000 mm	6000 mm	3000 mm	4000 mm
Y axis	1500 mm	2000 mm	2000 mm	1500 mm	2000 mm
Z axis	115 mm	115 mm	115 mm	115 mm	115 mm
Workpiece					
Max. weight	1800 kg ^[3]	3200 kg ^[3]	4800 kg ^[3]	900 kg	1700 kg
Max. speed					
Simultaneous	300 m/min	300 m/min	300 m/min	265 m/min	245 m/min
TRUMPF CNC control	Siemens Sinumerik 840D SL	Siemens Sinumerik 840D SL	Siemens Sinumerik 840D SL	Siemens Sinumerik 840D SL	Siemens Sinumerik 840D SL
Accuracy^[1]					
Position deviation P _a	0.05 mm	0.05 mm	0.05 mm	0.05 mm	0.05 mm
Average position scatter P _{s max}	0.03 mm	0.03 mm	0.03 mm	0.03 mm	0.03 mm
Dimensions and weight^[2]					
Length	9950 mm	12510 mm	16930 mm	8800 mm	11400 mm
Width	4600 mm	5400 mm	5420 mm	4800 mm	5430 mm
Height	2400 mm	2400 mm	2500 mm	2400 mm	2400 mm
Weight	12000 kg	14000 kg	17000 kg	12000 kg	13000 kg
Available lasers	TruFlow 6000/8000	TruFlow 6000/8000	TruFlow 6000/8000	TruDisk 3001/5001/8001	TruDisk 3001/5001/8001

^[1] Position scatter information is given in reference to the entire working length. Positional accuracy is measured and approved according to VDI/DGQ 3441.

^[2] Approximate values. The exact figures can be obtained from the applicable installation plan.

^[3] This information applies to one pallet. The maximum weight for two pallets is not represented here. Subject to alteration. Only specifications in our offer and order confirmation are binding.

Laser data					
	TruFlow 6000	TruFlow 8000	TruDisk 3001	TruDisk 5001	TruDisk 8001
Max. power	6000 W	8000 W	3000 W	5000 W	8000 W
Wavelength	10.6 µm	10.6 µm	1.03 µm	1.03 µm	1.03 µm
Max. sheet thickness					
Mild steel	25 mm	25 mm	20 mm	25 mm	25 mm
Stainless steel	25/30 ^[4] mm	50 mm	15 mm	20/25 ^[5] mm	20/40 ^[5] mm
Aluminum	15/20 ^[4] mm	25 mm	15 mm	20/25 ^[5] mm	20/25 ^[5] mm
Copper	–	–	6 mm	10 mm	10 mm
Brass	–	–	6 mm	10 mm	10 mm
Power consumption					
Average power consumption during production	31.6 kW	40.8 kW	11.9 kW	14.8 kW	19.8 kW
Active auto-shutdown	1.2 kW	1.2 kW	0.5 kW	0.5 kW	0.9 kW

^[4] With mirror cutting head.

^[5] With BrightLine fiber.

Subject to alteration. Only specifications in our offer and order confirmation are binding.

TruLaser Series 7000

High-performance machines.

The TruLaser Series 7000 stands for absolute top performance when it comes to productivity and accuracy. The machine's extremely rigid construction, linear direct drives, and high-resolution measurement systems ensure precision combined with maximum dynamics – both today and for many years to come. The dual-head technology deploys its full capabilities when processing medium and high sheet thicknesses, effortlessly halving cutting times.



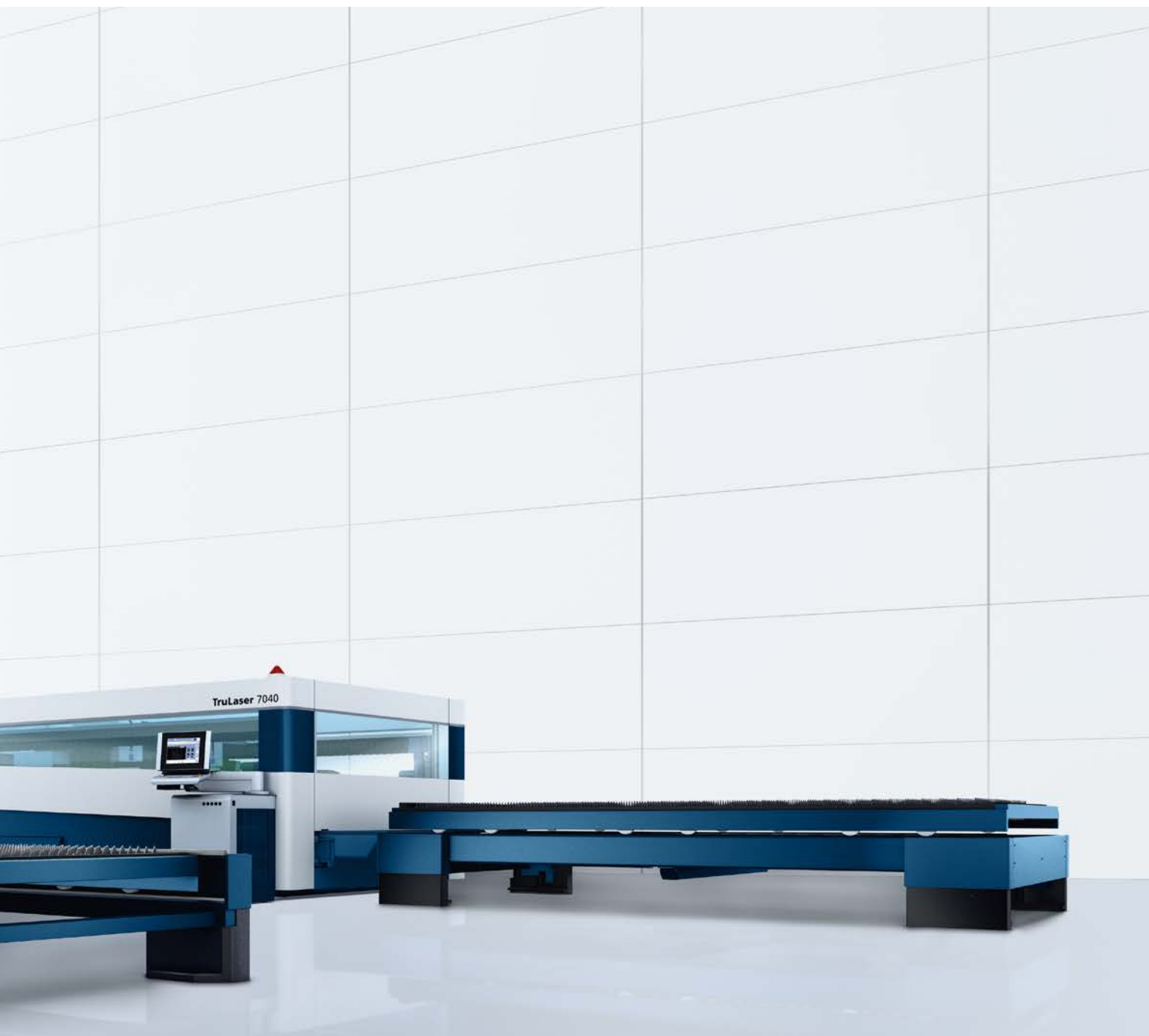

Benefits at a glance.

- 1 Maximum productivity with second cutting head.
- 2 Highest dynamics thanks to linear drives on all axes.
- 3 Absolute precision through high-resolution measurement systems in all axes.

TruLaser Series 7000

Unrivalled productivity.

With their high acceleration and axis speeds, these machines produce truly astonishing results. Compared with a single-head machine, you increase your throughput by 70–80%.

The TruLaser Series 7000 combines the high productivity of its linear drive technology with a unique laser concept. You can decide whether you want to produce parts with one or two cutting heads. The machine splits the beam of the TruDisk laser into two for dual-head operation or uses the whole beam for single-head operation. The two cutting heads on the CO₂ machine each have their own TruFlow laser and can each be taken offline separately as required.



Twice the productivity with two cutting heads.

Unrivalled precision.

High-resolution, direct measuring systems in all axes, combined with precise laser control, ensure excellent accuracy. As a result, this machine is perfect for cutting detailed parts, such as electrical panels.



Bracket, stainless steel, 6 mm.



Electrical panel, structural steel, 0.5 mm.

Machine data

	TruLaser 7040	TruLaser 7025 fiber	TruLaser 7040 fiber
Working range			
X axis	2500 mm	2500 mm	2500 mm
Y axis	4000 mm	1250 mm	4000 mm
Z axis	105 mm	100 mm	100 mm
Workpiece			
Max. weight	2000 kg	500 kg	1600 kg
Max. speed			
Simultaneous	304 m/min	304 m/min	304 m/min
TRUMPF CNC control	Siemens Sinumerik 840D SL	Siemens Sinumerik 840D	Siemens Sinumerik 840D
Accuracy^[1]			
Position deviation P _a	0.03 mm	0.03 mm	0.03 mm
Average position scatter P _{s max}	0.02 mm	0.02 mm	0.02 mm
Dimensions and weight^[2]			
Length	15800 mm	11900 mm	16800 mm
Width	7280 mm	7700 mm	8100 mm
Height	3090 mm	3500 mm	3500 mm
Weight	16500 kg	10400 kg	15000 kg
Available lasers	TruFlow 3200/4000/6000	TruDisk 6001	TruDisk 6001

^[1] Position scatter information is given in reference to the entire working length. Positional accuracy is measured and approved according to VDI/DGQ 3441.

^[2] Approximate values. The exact figures can be obtained from the applicable installation plan.

Subject to alteration. Only specifications in our offer and order confirmation are binding.

Laser data

	2x TruFlow 3200	2x TruFlow 4000	2x TruFlow 6000	TruDisk 6001
Max. power	2 x 3200 W	2 x 4000 W	2 x 6000 W	6000 W
Wavelength	10.6 µm	10.6 µm	10.6 µm	1.03 µm
Max. sheet thickness				
Mild steel	20 mm	20 mm	25 mm	20 mm
Stainless steel	12 mm	15 mm	25 mm	20 mm
Aluminum	8 mm	10 mm	15 mm	20 mm
Copper	–	–	–	6 mm
Brass	–	–	–	6 mm
Power consumption				
Average power consumption during production	54.2 kW	54.8 kW	65.3 kW	27.0 kW
Active auto-shutdown	1.6 kW	1.6 kW	1.8 kW	1.1 kW

Subject to alteration. Only specifications in our offer and order confirmation are binding.

TruLaser Series 8000

Flexible oversize format machines.

These machines are built to offer maximum cost-efficiency when processing oversized formats. Their unique extra pallet concept means they can process metal sheets up to 16 m in length while retaining the flexibility and productivity of a machine for standard formats. The metal sheet is moved through the machine in several steps, while intelligent processes ensure maximum part quality, even when the sheet is being repositioned.





Benefits at a glance.

- 1 Sheets up to 16 m in length.
- 2 Flexible choice of pallet system.
- 3 Smooth, seamless cutting of repositioned sheets.
- 4 Option of doubling productivity by adding a second cutting head.

TruLaser Series 8000

Powerful, reliable and productive.

The TruLaser Series 8000 demonstrates decisive advantages in oversized processing. With dynamic linear drives and proven TruFlow lasers you can be sure of achieving the highest cut quality. The patented solution for quick and precise pallet sequencing, combined with an intelligent monitoring and control system, guarantees reliable processes. As an option, you can double the productivity with a second cutting head.

Smart, controlled and precise.

Innovative processing strategies from TRUMPF provide the best quality assurance for your oversized format cutting. Control of the internal material stresses produces cuts without offset steps – for sheets up to 16 m in length. High resolution, direct measurement systems in all axes ensure extremely accurate parts. With the precise laser control system you will be able to cut contours reliably in thick and thin sheets.

The most cost-efficient strategy for your pallet changers.

The best solution if oversized formats account for **up to approx. 40% of your work:**

For standard formats up to 4 m in length use the pallet changer (1) and automation for highest productivity. You can enhance flexibility with the additional pallet (2) for sheets up to 16 meters in length.

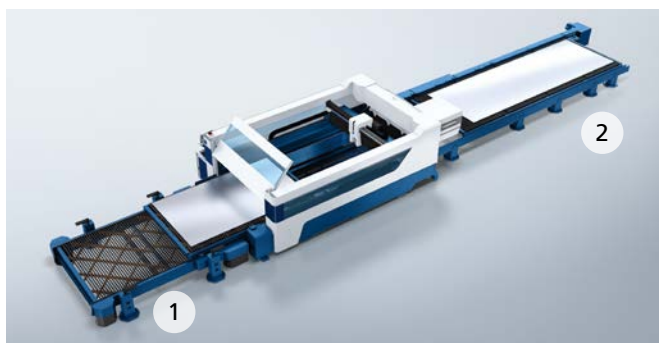

Flexible with an additional oversized format pallet.

The best solution if oversized formats account for **more than approx. 40% of your work:**

Achieve maximum productivity for oversized formats up to 12 m in length by loading and unloading while the machine is cutting. You can reduce cycle times to a minimum with the quick oversized pallet changer. This solution also enables cost-efficient unmanned production with maximum process reliability.

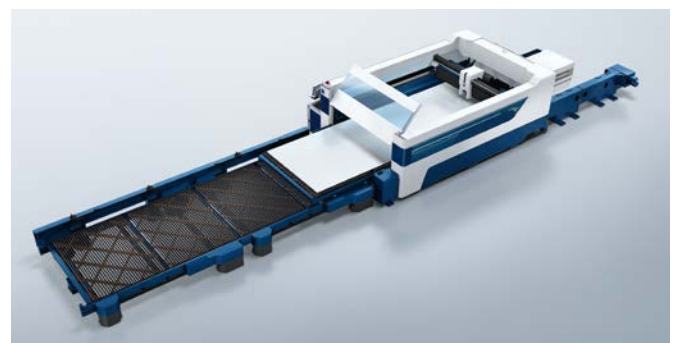

Highly productive with an oversized format pallet changer.

Machine data	
	TruLaser 8000
Working range	
X axis	2500 mm
Y axis	4000 mm
Z axis	105 mm
Oversized format options	
With 4000 x 2500 mm pallet changer and additional oversized format pallet	16000/14000/12000/10000/8000/6000 x 2500 mm
With oversized format pallet changer	12000/8000/6000 x 2500 mm
Workpiece	
Max. weight	Depends on selected pallet system
Max. speeds	
Simultaneous	304 m/min
TRUMPF CNC control	Siemens Sinumerik 840D SL
Accuracy⁽¹⁾	
Position deviation P_a	0.05 mm
Average position scatter $P_{s\ max}$	0.03 mm
Repeat accuracy of repositioning	± 0.1 mm
Position accuracy of repositioning	± 0.2 mm
Dimensions and weight	Depends on selected pallet system

⁽¹⁾ Position scatter information is given in reference to the entire working length. Positional accuracy is measured and approved according to VDI/DGQ 3441. Subject to alteration. Only specifications in our offer and order confirmation are binding.

Laser data		
	TruFlow 4000	TruFlow 6000
Max. power	4000 W	6000 W
Wavelength	10.6 µm	10.6 µm
Max. sheet thickness		
Mild steel	20 mm	25 mm
Stainless steel	15 mm	25 mm
Aluminum	10 mm	15 mm
Power consumption		
Average power consumption during production	30.3 kW	38.2 kW
Active auto-shutdown	1.0 kW	1.2 kW

Subject to alteration. Only specifications in our offer and order confirmation are binding.

Focused knowledge.

TRUMPF machines are very well equipped for all current demands in sheet metal processing and achieve optimal results. To address specific requirements as well, and simplify operation even further, we are continuously developing innovations, such as regulatory, control functions and sensor systems.

For special requirements, you can expand your production capabilities with our innovative Lines – you will find a selection here. Our assistance systems, such as the smart functions, help you with your daily work. Besides Lines and assistance systems, clever features also optimize your production process.

Productivity, reliability and high quality – these Lines, smart functions and clever features can help you improve your workflow.

↗ Productivity ↻ Process reliability ✓ Quality

▶ AdjustLine



Adapting to material quality made easy.

AdjustLine makes it easier to process lower-quality material. The function adjusts cutting parameters to ensure process reliability when cutting parts.

▶ CoolLine



Cut even thick mild steel intricately.

The selective cooling of the workpiece during the cutting process allows for new geometries, more efficient sheet utilization and significantly increases process reliability in the processing of thick mild steel. This process is part of the single cutting head strategy.

▶ BrightLine



Excellent through thick and thin.

This special cutting system produces the highest quality cuts in thick stainless, mild steel and aluminum. The smoothness and squareness of the cut edge are far superior to a standard cut. No finishing work is required.

▶ DetectLine



Precise position recognition and automatic setting of the focal position.

A camera system determines the precise position of sheets being processed, and also enables the precise further processing of parts which have already been cut. In addition, DetectLine automatically adjusts the focus position.

▶ Dot Matrix Code



Marking parts fast and reliably.

In just a few seconds, the laser in your flatbed machine applies a 2-dimensional code (data matrix) of dots to the part being processed. The code content is defined during the programming stage and contains information for the sheet metal processing chain. This considerably simplifies production processes.

▶ LensLine



Protection for lens and machine.

LensLine switches off the beam as soon as there are critical impurities within the focusing lens. In doing so the lens is prevented from thermal decomposition, and the beam guidance stays clean. LensLine additionally offers a condition checking function which, thanks to the RFID lens, guarantees perfectly timed cleaning cycles.

▶ FlyLine



Pierce on the fly and process faster.

The cutting head travels at high speed over the entire sheet line by line. The control system cuts all the contour sections in the respective beam path. This reduces the time spent on traversing and positioning, especially when cutting perforated grids.

▶ PierceLine



Everything under control when piercing.

PierceLine monitors and controls the piercing process. This reduces stress on the material and machine and shortens pierce time by up to 80%.

▶ FocusLine



Adapt focal position automatically.

An adaptive mirror in the beam guidance system makes it possible to automatically adjust the focus position to the material type and thickness. The result: Maximum processing speed and excellent edge quality across the entire range of surfaces and materials – without the need for manual adjustment.

▶ Smart Collision Prevention



Safe without microjoints.

Smart collision prevention creates a processing strategy that applies across components. Parts at risk of tipping over are cut free only when there is no longer any risk of collision. This allows you to work reliably and safely, even without microjoints.

Focused knowledge.

► Single cutting head strategy



Save time by using a single cutting head that does not require changing. This reduces non-productive time, especially when you are automatically processing a number of different materials.

► High-speed cutting



A special cutting head selectively introduces metal vapor plasma to significantly increase cutting speed.

► Laser output control



The laser power output is automatically adapted to the cutting speed. This ensures optimum cut quality even on sharp corners and small contours.

► Drop&Cut



Drop&Cut makes the use of remainder sheets and the post-production easier, more intuitive, and efficient than ever. A camera projects the live image of the machine interior directly onto the user interface. Now you can use the mouse or touch control to flexibly place geometries on the remainder sheet.

	TruLaser Series 1000	TruLaser Series 3000*	TruLaser Series 5000*	TruLaser Series 7000*	TruLaser Series 8000
AdjustLine		■ □	■ □	■	■
BrightLine ⁽¹⁾		■	■	■	■
BrightLine fiber ⁽¹⁾		□	□		
CoolLine ⁽¹⁾		■	■ □	■	■
DetectLine ⁽¹⁾		■ □	■ □		
Dot Matrix Code ⁽¹⁾			■ □		
Drop&Cut ⁽¹⁾		■ □	■ □	■	■
Single cutting head strategy	■ □	■ □	■ □	■ □	■
FlyLine		■ □	■ □	■ □	■
FocusLine	■ □	■ □	■ □	■ □	■
High-speed cutting ⁽¹⁾		■	■	■	■
Laser output control	■ □	■ □	■ □	■ □	■
LensLine		■	■	■	■
PierceLine	□	■ □	■ □	■	■
Smart Collision Prevention ⁽¹⁾		■ □	■ □		
Smart Nozzle Automation ⁽¹⁾			■ □		

■ CO₂ □ SSL * Subject to variability. Please contact your TRUMPF sales person for further details.

⁽¹⁾ Optional

BrightLine fiber

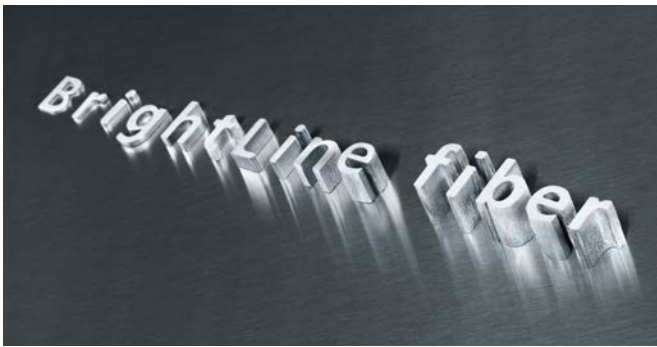

Top-quality results without compromises.

BrightLine fiber turns solid-state lasers into all-purpose tools: it enables you to achieve top-quality results for every sheet metal thickness. What's more, the solid-state laser's benefits for thin-sheet metal processing remain unchanged.

1. Higher quality

Process sheet metal with outstanding edge quality.

2. Increased flexibility

Expand the range of sheet thicknesses you are able to process using the same laser power.

3. Maximum piercing quality

Thanks to BrightLine fiber and multi-stage piercing, there is no spatter even with the smallest of piercing holes.

4. Tiny contours

BrightLine fiber enables you to process even smaller contours than before. Small holes that formerly could only be drilled can now be cut by laser.

5. Higher process stability

BrightLine fiber provides all-round process stability, even with the most exacting cutting quality requirements.

6. Simple part removal

BrightLine fiber makes it easier to remove parts from the scrap skeleton. This saves valuable time when sorting parts. An even cutting surface and a wider kerf are responsible for this easier part removal.

Smart Nozzle Automation



Process reliability in fully automated operation.

Smart nozzle automation bundles clever features that provide process reliability in fully automated operation. In doing this, this smart function





ensures, among other things, the autonomous changing of nozzles when necessary. The nozzle inspection reliably determines whenever a change is necessary. Be it for CO₂ or solid-state laser technologies, smart nozzle automation always includes the relevant functionalities.

Automation that pays off.

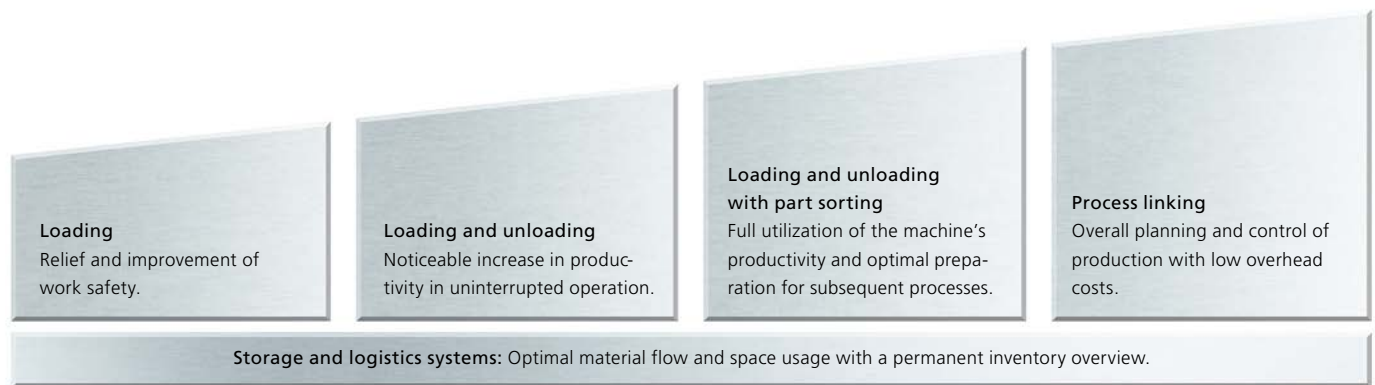
Profitable and efficient production with automation options from TRUMPF.

Automated machines support the material flow, increase process reliability and enhance productivity. TRUMPF's multi-stage concept offers automation that meets your individual needs – all the way through to completely automated production. The solutions come from a single source and are perfectly tailored to TRUMPF machines.



Automation function	Loading		Loading and unloading	
	LoadMaster	LiftMaster	LiftMaster Compact	LiftMaster Sort
				
Possible machines:				
TruLaser Series 1000				
TruLaser Series 3000	■	■	■	■
TruLaser Series 5000	■	■	■	■
TruLaser Series 7000	■	■	■	■
TruLaser Series 8000	■	■		■

- **LoadMaster** – entry-level solution for the loading of the pallet changer.
- **LiftMaster** – universal loading and unloading.
- **LiftMaster Sort** – loading and unloading with separation of large parts.
- **LiftMaster Compact** – compact and quick loading and unloading.
- **LiftMaster Linear** – loading and unloading of up to three machines.
- **LiftMaster Store** – loading and unloading with direct storage connection.
- **LiftMaster Store Linear** – loading and unloading of up to three machines with direct storage connection.
- **SortMaster** – separation and sorting of small parts. Requires a loading and unloading solution.
- **TruStore** – modular, expandable rack and storage system.
- **Customized storage** – individual storage solution for special requirements.

Loading and unloading / part sorting				Storage and logistics systems	
LiftMaster Linear	LiftMaster Store	LiftMaster Store Linear	SortMaster	TruStore	Customized storage
					
■	■	■	■	■	■
■	■	■	■	■	■
■	■	■	■	■	■
■	■	■	■	■	■

Software:

Programmed for success.

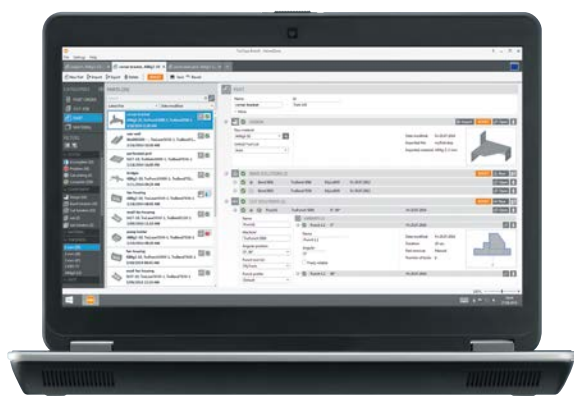

TruTops Boost takes you faster than ever from the geometry to the NC program.

TRUMPF's TruTops Boost is the software solution for designing and programming laser, punching and bending machines that lets you increase your performance at the touch of a button. The software combines all order processing steps, from the geometry through to the completed NC program, in a single all-in-one solution. Its new operating philosophy guides you through the software in a simple, process-oriented manner while allowing you to keep an overview of your orders. Thanks to its numerous automated functions, the innovative Boost technology also makes you unbeatably fast. With it, you become more profitable and boost your business!

Talk to your TRUMPF contact to find out when TruTops Boost will be available to you. Until then, our TruTops Laser software can offer you optimum support. We recommend our TruTops Fab software as the ideal production control system for your requirements.

TruTops Boost: Benefits at a glance.

- From geometry to NC program faster than ever before.
- Everything monitored: Single software solution for all order processes.
- Everything under control: Intuitive user interface supports flexible working.
- Everything faster: Boost technology with productive automated functions.
- Innovative Boost technology + new operating philosophy = TruTops Boost

TruServices:

Service like
no other.

Throughout the lifecycle of your machine.

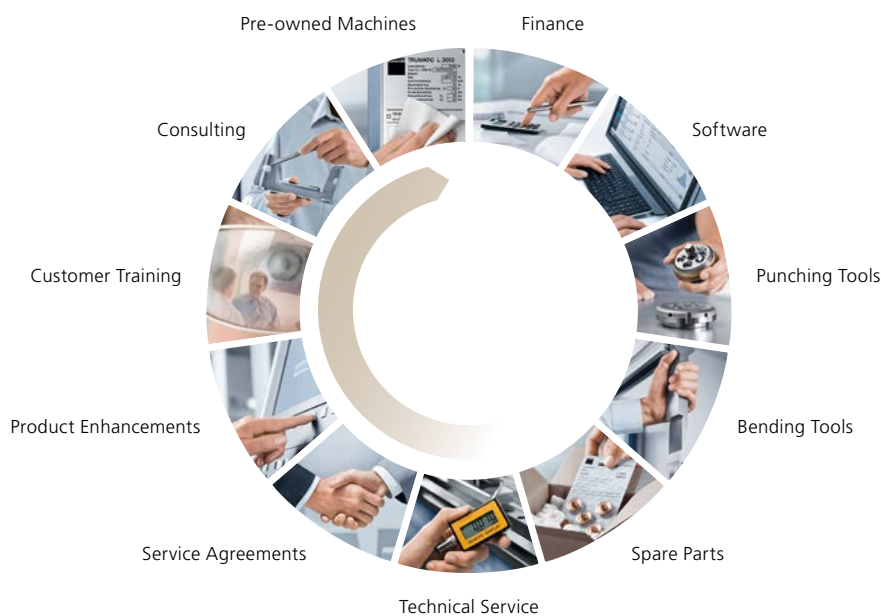

Regardless of the TRUMPF technology you use, you will always get the best service. Thanks to the award-winning spare parts logistics at TRUMPF, we guarantee the highest availability of spare parts and provide you with all the products in the shortest time. TruServices Finance offers you individual financing solutions quickly and without a lot of paperwork. Our service technicians are highly trained and always available when you

need them. A Service Agreement is the ideal way of ensuring the best usability of your machine. Should your requirements change, we have flexible upgrading options and technical innovations that will make your machine even better. Our broad range of training courses with experienced trainers and hands-on practice will also give you a head start in understanding and operating your machine.

The TRUMPF Group ranks among the world's leading manufacturers of production technology and industrial lasers. Technical and efficient solutions for our customers have been our focus since 1923. As a leading technology supplier, TRUMPF is a one-stop shop for all of your technology needs: machines, automation, storage technology and services.

TRUMPF is certified according to ISO 9001:2008
(for additional information see www.trumpf.com/en/company/quality)

Ident no. 1787269_201504_F – Content subject to change without notice